



Stačiakampiai kanaliniai ventiliatoriai

Rectangular duct fans

Rechteckige Kanalventilatoren

Прямоугольные каналные вентиляторы



Stačiakampiai kanaliniai ventiliatoriai, skirti vėdinimo ir oro kondicionavimo sistemoms, montuojami į stačiakampių ortakių sistemą. Naudojami oro tiekimui ir šalinimui. Nenaudojami užteršto oro, agresyvių, sprogių dujų transportavimui. Kompaktiški, tyliai dirbantys, montuojami bet kokioje padėtyje, sparnuotė lengvai iškeliami valymui.

Sparnuotė: atgal lenktais sparneliais, plastmasinė arba cinkuoto plieno.

Variklis: išorinis rotorius, tiesioginė pavara, integruota termokontaktinė variklio apsauga, ilgai tarnaujantys nereikalaujantys priežiūros guoliai.

Korpusas: iš cinkuotos skardos.



Rechteckige Kanalventilatoren, die für Lüftungs- und Klimaanlagen bestimmt sind, werden in das System der rechteckigen Luftführungskanäle montiert. Sie werden für Zuluft und Abluft verwendet. Nicht geeignet für die Beförderung von verschmutzter Luft, aggressiven, explosiven Gasen. Kompakt, leise funktionierend, Montage in jeder beliebigen Stellung, das Flügelwerk ist leicht zur Reinigung herausnehmbar.

Laufblad ist rückwärts gekrümmt, aus Kunststoff bzw. verzinktem Stahl.

Der Motor: Außenrotor, Direktantrieb, integrierter Thermokontakt-Motorschutz, dauerhafte, keine Pflege erfordernde Lager.

Das Gehäuse: aus verzinktem Blech.



Rectangular ducts fans for ventilation and air conditioning systems, mounted into a system of rectangular air ducts. Used for the air supply or extract. Not suitable for polluted air, aggressive and explosive gases. Compact, mounted in any position. Easily opened doors for cleaning an impeller.

Impeller with backward curved blades, made of plastic or galvanized steel.

Motor: external rotor, motor protection built-in thermal-contact, free-maintenance ball bearings.

Housing: made of galvanized steel.



Прямоугольные каналные вентиляторы для систем вентиляции и кондиционирования, устанавливаются в систему прямоугольных воздуховодов. Эксплуатируются в целях подачи и вытяжки воздуха. Не используются при транспортировке загрязнённого воздуха, агрессивных, взрывоопасных газов. Компактные, бесшумные, устанавливаются в любом положении, крыльчатка легко извлекается для чистки.

Крыльчатка: загнутые назад лопасти, пластмасса или оцинкованная сталь.

Двигатель: наружный ротор, прямая передача, встроенные термоконтакты двигателя, не требующие ухода подшипники с длительным сроком службы.

Корпус: оцинкованной жести.

Accessories



LJ/E
LJ/PG
p. 183-184



SKS
p. 157



FDS
p. 151



EKS
p. 122



LG
p. 178

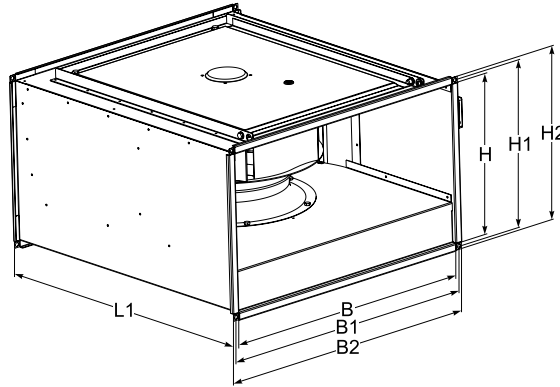

Type	Dimensions [mm]						
	B	B1	B2	H	H1	H2	L1
VKSB 300x150	300	320	340	150	170	190	400
VKSB 400x200	400	420	440	200	220	240	445
VKSB 500x250	500	520	540	250	270	290	530
VKSB 500x300	500	520	540	300	320	340	560
VKSB 600x300	600	620	640	300	320	340	640
VKSB 600x350	600	620	640	350	370	390	700
VKSB 700x400	700	720	740	400	420	440	780
VKSB 800x500	800	820	840	500	520	540	880
VKSB 1000x500	1000	1020	1040	500	520	540	980

Accessories



TGRV
p. 143



TGRT
p. 144



MTY
p. 146

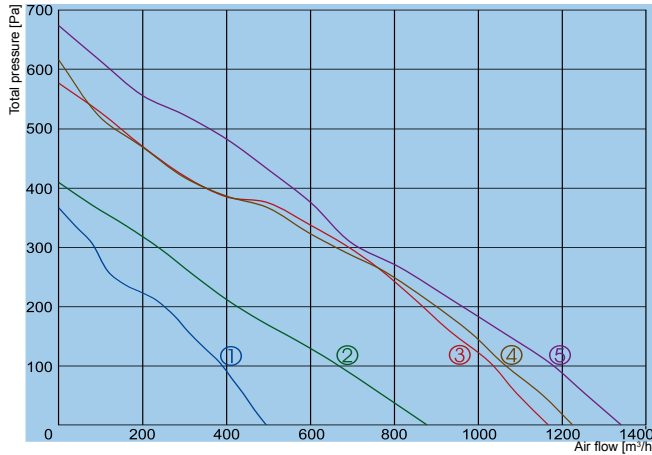

- ① — VKSB 300x150-2 L1
- ② — VKSB 400x200-2 L1
- ③ — VKSB 400x200-2S L1
- ④ — VKSB 500x250-2 L1
- ⑤ — VKSB 500x250-2S L1

		300x150-2 L1	400x200-2 L1	400x200-2S L1	500x250-2 L1	500x250-2S L1
Voltage/Frequency	[V/Hz]	230/50	230/50	230/50	230/50	230/50
Power consumption	[kW]	0,058	0,085	0,135	0,135	0,155
Current	[A]	0,26	0,38	0,60	0,60	0,70
Speed	[min ⁻¹]	2500	2600	2650	2650	2600
Max. airflow	[m ³ /h]	494	878	1166	1229	1342
Max. air temperature	[°C]	50	40	60	60	50
Total sound pressure level at 1 m	[dBA]	62	73	69	69	75
Speed controller		TGRV1,5/MTY0	TGRV1,5/MTY0	TGRV1,5/MTY1	TGRV1,5/MTY1	TGRV1,5/MTY1
Weight	[kg]	5,0	8,0	8,0	16,0	16,0
Wiring diagram		No. 1	No. 1	No. 1	No. 1	No. 1
Protection class:	motor	IP-44	IP-44	IP-44	IP-44	IP-44
	terminal box	IP-54	IP-54	IP-54	IP-54	IP-54

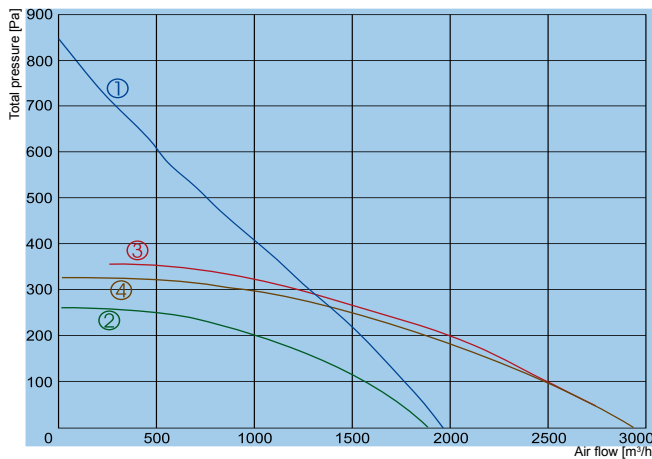

- ① — VKSB 500x300-2 L1
- ② — VKSB 500x300-4 L3
- ③ — VKSB 600x300-4 L1
- ④ — VKSB 600x300-4 L3

		500x300-2 L1	500x300-4 L3	600x300-4 L1	600x300-4 L3
Voltage/Frequency	[V/Hz]	230/50	400/50	230/50	400/50
Power consumption	[kW]	0,225	0,15	0,31	0,27
Current	[A]	1,0	0,36	1,35	0,47
Speed	[min ⁻¹]	2700	1400	1370	1310
Max. airflow	[m ³ /h]	1964	1880	2930	2930
Max. air temperature	[°C]	40	70	65	60
Total sound pressure level at 1 m	[dBA]	76	73	78	77
Speed controller		TGRV1,5/MTY2	TGRT1	TGRV1,5/MTY2	TGRT1
Weight	[kg]	17,0	18,0	19,0	21,0
Wiring diagram		No. 1	No. 3	No. 2	No. 3
Protection class:	motor	IP-44	IP-54	IP-54	IP-54
	terminal box	IP-54	IP-54	IP-54	IP-54

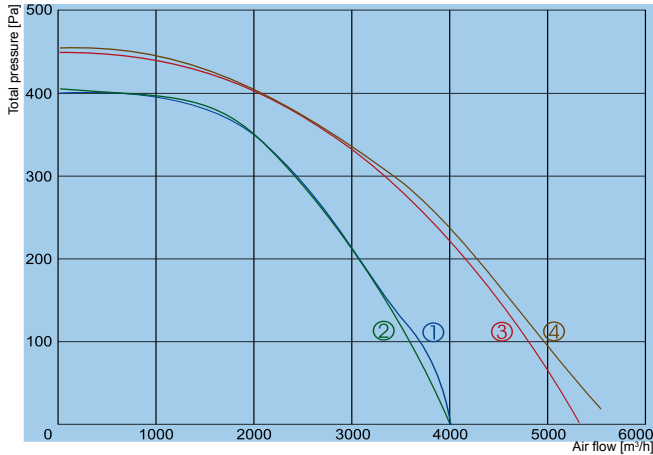

- ① — VKSB 600x350-4 L1
- ② — VKSB 600x350-4 L3
- ③ — VKSB 700x400-4 L1
- ④ — VKSB 700x400-4 L3

		600x350-4 L1	600x350-4 L3	700x400-4 L1	700x400-4 L3
Voltage/Frequency	[V/Hz]	230/50	400/50	230/50	400/50
Power consumption	[kW]	0,52	0,46	0,74	0,69
Current	[A]	2,2	0,85	3,2	1,3
Speed	[min ⁻¹]	1360	1340	1280	1230
Max. airflow	[m ³ /h]	4010	4000	5330	5540
Max. air temperature	[°C]	40	55	60	40
Total sound pressure level at 1 m	[dBA]	77	77	83	83
Speed controller		TGRV3/MTY4	TGRT1	TGRV4/MTY4	TGRT2
Weight	[kg]	24,0	27,0	48,0	64,0
Wiring diagram		No. 2	No. 3	No. 2	No. 3
Protection class:	motor	IP-54	IP-54	IP-54	IP-54
	terminal box	IP-54	IP-54	IP-54	IP-54

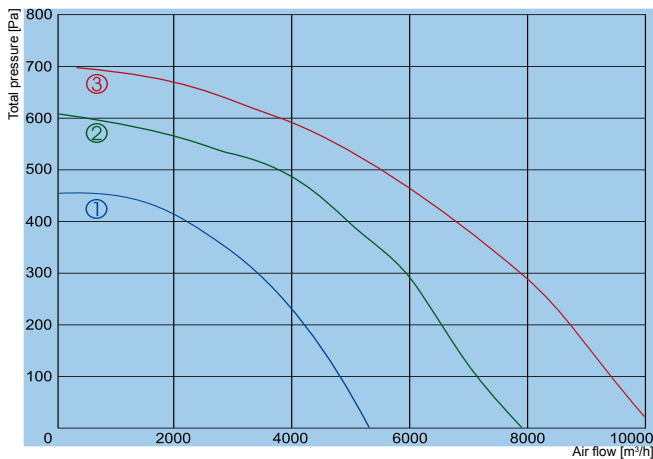

- ① — VKSB 800x500-4 L1
- ② — VKSB 800x500-4 L3
- ③ — VKSB 1000x500-4 L3

		800x500-4 L1	800x500-4 L3	1000x500-4 L3
Voltage/Frequency	[V/Hz]	230/50	400/50	400/50
Power consumption	[kW]	0,74	1,25	1,8
Current	[A]	3,2	2,3	3,4
Speed	[min ⁻¹]	1280	1340	1230
Max. airflow	[m ³ /h]	5300	7900	10000
Max. air temperature	[°C]	60	45	40
Total sound pressure level at 1 m	[dBA]	83	85	86
Speed controller		TGRV4/MTY4	TGRT3	TGRT4
Weight	[kg]	56,0	69,0	89,0
Wiring diagram		No. 2	No. 3	No. 3
Protection class:	motor	IP-54	IP-54	IP-54
	terminal box	IP-54	IP-54	IP-54

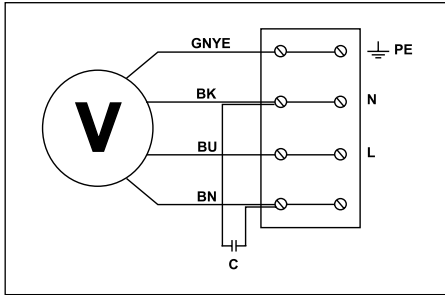

Wiring diagram No. 1 (1~230V)

GNYE - green-yellow
 BK - black
 BU - blue
 BN - brown

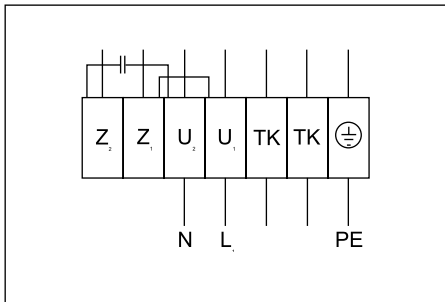

Wiring diagram No. 2 (1~230V)

U₁ = brown
 U₂ = blue
 Z₁ = black
 Z₂ = orange
 TK = white

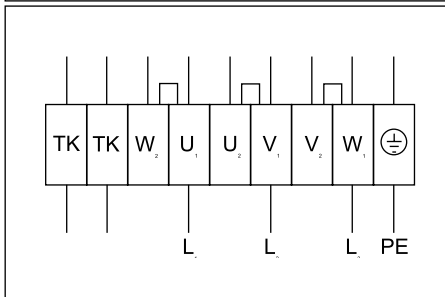

Wiring diagram No. 3 (Δ - 3~400V)

U₁ = brown
 U₂ = red
 V₁ = blue
 V₂ = grey
 W₁ = black
 W₂ = orange
 TK = white

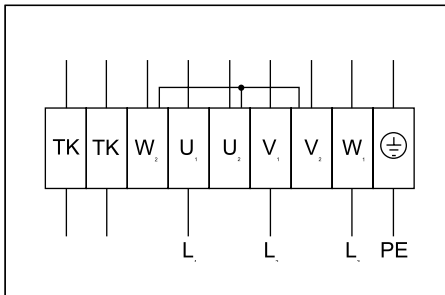

Wiring diagram No. 3 (Y - 3~400V)

U₁ = brown
 U₂ = red
 V₁ = blue
 V₂ = grey
 W₁ = black
 W₂ = orange
 TK = white